

CUSTOMER NAME	
PROJECT NAME	
DATE	TYPE
CATALOG NUMBER	

Arize Factor® ML300 HORT147

Scalable lighting system for multi-layer cultivation

Scalable, modular, and versatile, the Arize Factor ML300 is the ideal choice for multi-layer, production-focused cultivation. Configurable in 4-, 5-, and 6-bar arrays, growers can add extra bars to easily boost intensity or increase coverage area. This highly efficient, passively-cooled LED grow light system can power vigorous vegetative growth or drive generative production in dense, sea-of-green style indoor plantations.

Optical System

Typical Photon Flux	1134 - 1728 $\mu\text{mol/s}$
Light Distribution	140°
Spectrums	PKR, PKB, PKF

Ambient Temperature

TYPE	TEMPERATURE RATING
Operating Temperature	0°C to 40°C (32°F to 104°F)

Electrical

Dimming Range	0-10V
Max Source Current	450uA
Efficacy Range	2.7 to 2.8 $\mu\text{mol/j}$
Dim-to-Off ³	Yes
Dim Off Voltage	0.35-0.65V (typ. 0.5V)
Dim On Voltage	0.55-0.85V (typ. 0.7V)
Dimming Output Range	10%-100%
Power Factor	>0.9
Absolute Maximum Dimming Voltage	20V
Max. Remote Mount Distance	6 ft (1.83 m)
Cooling	Passive
IP Rating	IP65

For input voltage option 3, dimming control input is non-isolated from Class 1 driver output circuit. Use with sink dimmers only

³ Refer to installation guide for dimming functionality details

⁴ Tested at 40°C per TM-21

Rated Lifetime

L90: >50,000 hours⁴

Certifications & Warranty

Five-year system warranty
cULus E492907, CE, UKCA, DLC

CUSTOMER NAME	
PROJECT NAME	
DATE	TYPE
CATALOG NUMBER	

Ordering Information

GEHF

MODEL	MODEL	MOUNTING	SPECTRUM	INPUT VOLTAGE	DISTRIBUTION	OPTIONS	GEN	PACKAGING	
GEHF	M4	S Suspended U 1 5/8" Unistrut	PKR	2 120-277V	W Wide Batwing	X Leader Cable, Open Lead	1	[Blank] Single Pack	
			PKB	3 277-480V		5 NEMA 5-15P ⁵		M1 Bulk Pack	
			PKF			6 NEMA 6-15P ⁵			
	M5	5x MO bars, 1x 600W driver	S Suspended U 1 5/8" Unistrut	PKR	3 277-480V	W Wide Batwing	7 NEMA L7-15P ⁶	1	[Blank] Single Pack
				PKB			5 NEMA 5-15P ⁵		M1 Bulk Pack
				PKF			6 NEMA 6-15P ⁵		
	M6	6x MO bars, 1x 600W driver	S Suspended U 1 5/8" Unistrut	PKR	3 277-480V	W Wide Batwing	7 NEMA L7-15P ⁶	1	[Blank] Single Pack
				PKB			5 NEMA 5-15P ⁵		M1 Bulk Pack
				PKF			6 NEMA 6-15P ⁵		

⁵ Only available with input voltage option 2

⁶ Only available with input voltage options 2 or 3

SPECTRUM TABLE						
ARRAY	SPECTRUM	TYPICAL PHOTON FLUX ¹ (μMOL/S)	POWER ² (W)	EFFICACY ² (μMOL/J)	DC INPUT VOLTAGE	LIGHT BAR MODEL NUMBER ³
4-bar	PKR	1148	415	2.8	45	GEHF-MPKRW1
	PKB	1152	415	2.8	45	GEHF-MPKBW1
	PKF	1134	423	2.7	45	GEHF-MPKFW1
5-bar	PKR	1436	519	2.8	45	GEHF-MPKRW1
	PKB	1440	519	2.8	45	GEHF-MPKBW1
	PKF	1417	529	2.7	45	GEHF-MPKFW1
6-bar	PKR	1723	622	2.8	45	GEHF-MPKRW1
	PKB	1728	622	2.8	45	GEHF-MPKBW1
	PKF	1701	635	2.7	45	GEHF-MPKFW1

¹ Typical PPF +/-10% ² Tested at maximum input voltage of 480VAC ³ See Order Code Table on page 4 for ordering logic

ACCESSORIES

ORDER CODE	SKU	DESCRIPTION	BOX QUANTITY
GECA30A14-AA03B	93118692	3' Interconnection Cable, UL	60
GECA30A14-AA06B	93067607	6' Interconnection Cable, UL	32
GEHR-BRA WIREFORM	93153914	Factor Suspended Mount Wireform Bracket	1
GEHR-BRA WIREFORM 1X5/8	95052672	Factor Suspended Mount Wireform Bracket 1 5/8"	1
GEMB-BAW1	93153918	Factor Rolling Rack Mount, 24"	1
GEMB-BAW2	93153917	Factor Rolling Rack Mount, 48"	1
GEHAK-NN-NE-N0	95047411	1' Driver Remote Mounting Kit	1
GEHR-HAR M15 SHORTING CAP	93306044	Replacement Shorting Cap	1

Not all product variations listed on this page are DLC qualified. Visit qpl.designlights.org/horticulture to confirm qualification.

CUSTOMER NAME			
PROJECT NAME			
DATE		TYPE	
CATALOG NUMBER			

Product Dimensions

DIMENSIONS AND WEIGHT				
	LENGTH	WIDTH	HEIGHT	WEIGHT
Fixture	46.97" 1193 mm	3.58" 91 mm	2.08" 53 mm	5.7 lbs 2.6 kg
Power Supply	10.81" 274.5 mm	9.96" 252.9 mm	3.65" 92.8 mm	7.7 lbs 3.5 kg

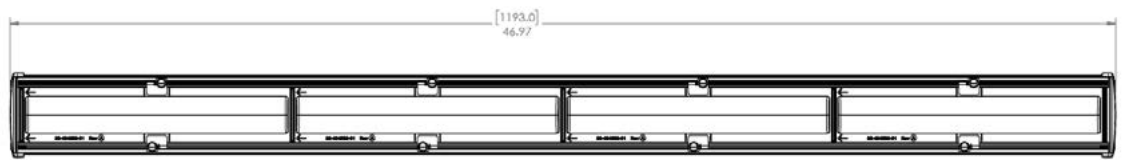
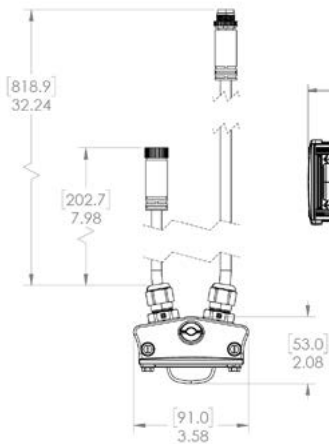

Photometric Data

Type R

High red light to optimize plant growth and photosynthesis

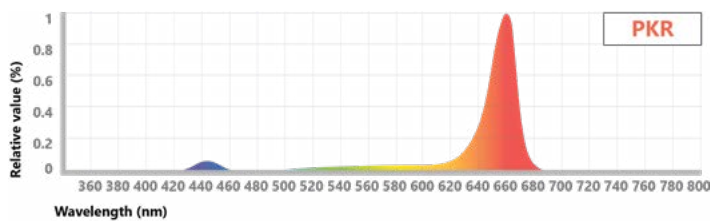

Type F

Encourages an expansion response for more robust growth

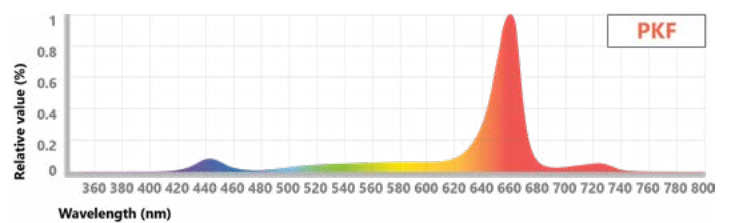

Type B

Light that supports biomass and secondary metabolite production

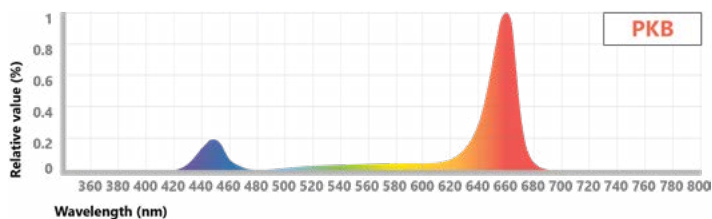

SPECTRUM PHOTON DISTRIBUTION				
Ratio	Blue PF	Green PF	Red PF	Far Red PF
PKR	7.0%	16.0%	76.0%	1.0%
PKB	15.0%	14.0%	70.0%	1.0%
PKF	7.0%	16.0%	72.0%	5.0%

CUSTOMER NAME	
PROJECT NAME	
DATE	TYPE
CATALOG NUMBER	

Why Factor?

1. Grow Cart Mount

Factor adapts to your grow, not the other way around. The system can be installed on the side of a grow cart using the transversal bar, allowing it to fit below ventilation systems.

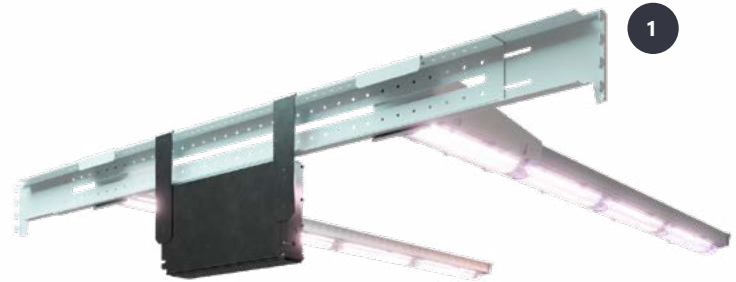

2. Suspended Mount

One size fits all. Straightforward hooks allow the light bars to be hung from any rack, and the power supply can be remotely mounted, meaning the Factor can be used in any setup.

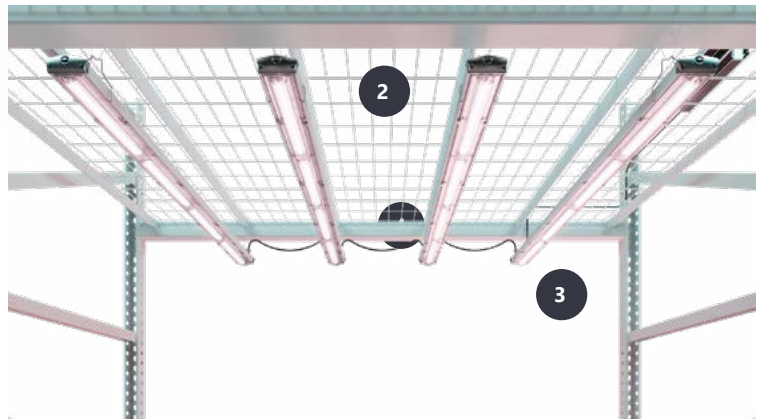

3. Reliability

We perform the most extensive, stringent testing in the industry. We test the LED, water and dust ingress protection, sub-system and complete system at our in-house and independent laboratories around the world. Validation of our designs, components, products and processes include high temperature, high humidity and accelerated life testing.

Arrays

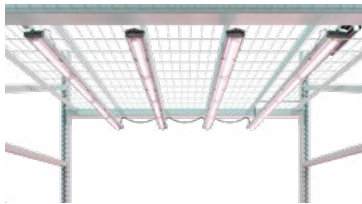

4-bar



5-bar



6-bar

The Factor ML300 adapts to your setup, not the other way around. Customize the number of bars and spacing for tailored coverage and PPFD.